

General

A small size CO₂ sensor module, suitable for limited space applications like Indoor Air Quality, HVAC, Stove, Air-conditioner, Vehicle drowsiness warning, Gas measurement and so on. S-100H is much favored by Customers due to the long life cycle and high accuracy. As one of the NDIR technology fabricated product, it supports one month period Auto-Recalibration and 10 minutes Manual-Recalibration as needed.

TCC ELT

Carbon Dioxide (CO₂) Module

Model : S-100H

Features

- Non-Dispersive Infrared (NDIR) technology used to measure CO₂ levels.
- Output mode : AVO, TTL UART, I2C
- Operation Mode
 - i. Factory Calibration Status Mode or
 - ii. Periodic Automatic Re-Calibration mode (ACDL :Automatic Re-Calibration in Dimming mode)
- ※ Sensor has only 1 mode selected on Customer's purchase.
- Re-Calibration Function Support
 - i. Low signal to pin 11 of S-100H for 11 minutes for MCDL or
 - ii. Using Re-Calibration Jig (TRB-100)
- Size : 39mmx32mmx18.5mm (small size)
- 2.5mm pitch header connector



S-100H

Specifications

General Performance

Operating Temperature

0 ~ 50°C

Operating Humidity

0 ~ 95% RH (Non-condensing)

Storage Temperature

-30°C ~70°C

CO₂ Measurement

Sensing Method

NDIR (Non-dispersive Infrared)

Measurement Range

0 to 2,000/3,000/5,000/10,000/30,000ppm
(Optional)

Accuracy

±30ppm ±5% of measured value

Step Response Time(90%)

60 seconds

Sampling Interval

3 seconds

Electrical Data

Power Input

12VDC (9 ~ 18VDC, ±10% Regulation)

Current consumption

Normal : 16mA

Max : 400mA at lamp on peak

Output connector

11 pin header connector

Output Signal

UART

38,400BPS, 8bit, No parity, 1 stop bit

TTL Level Voltage 3.3~4.5V

I2C

Slave mode only

Internal pull up resister

Under 400Khz Clock

TTL Level Voltage 3.3~4.5V

Analog Voltage Output

VDC 0.5 ~ 4.5V

Pin Description

Pin No.	Description
1	I2C SDA
2	I2C SCL
3	12VDC Power Supply
4	Reset (Low Active)
5	Reserved (Don't connect)
6	GND
7	TXD (UART)
8	RXD (UART)
9	Reserved (Don't connect)
10	Analog Output (0.5~4.5V)
11	10 min. Manual Re-Calibration(MCDL)

Dimensions (unit : mm)

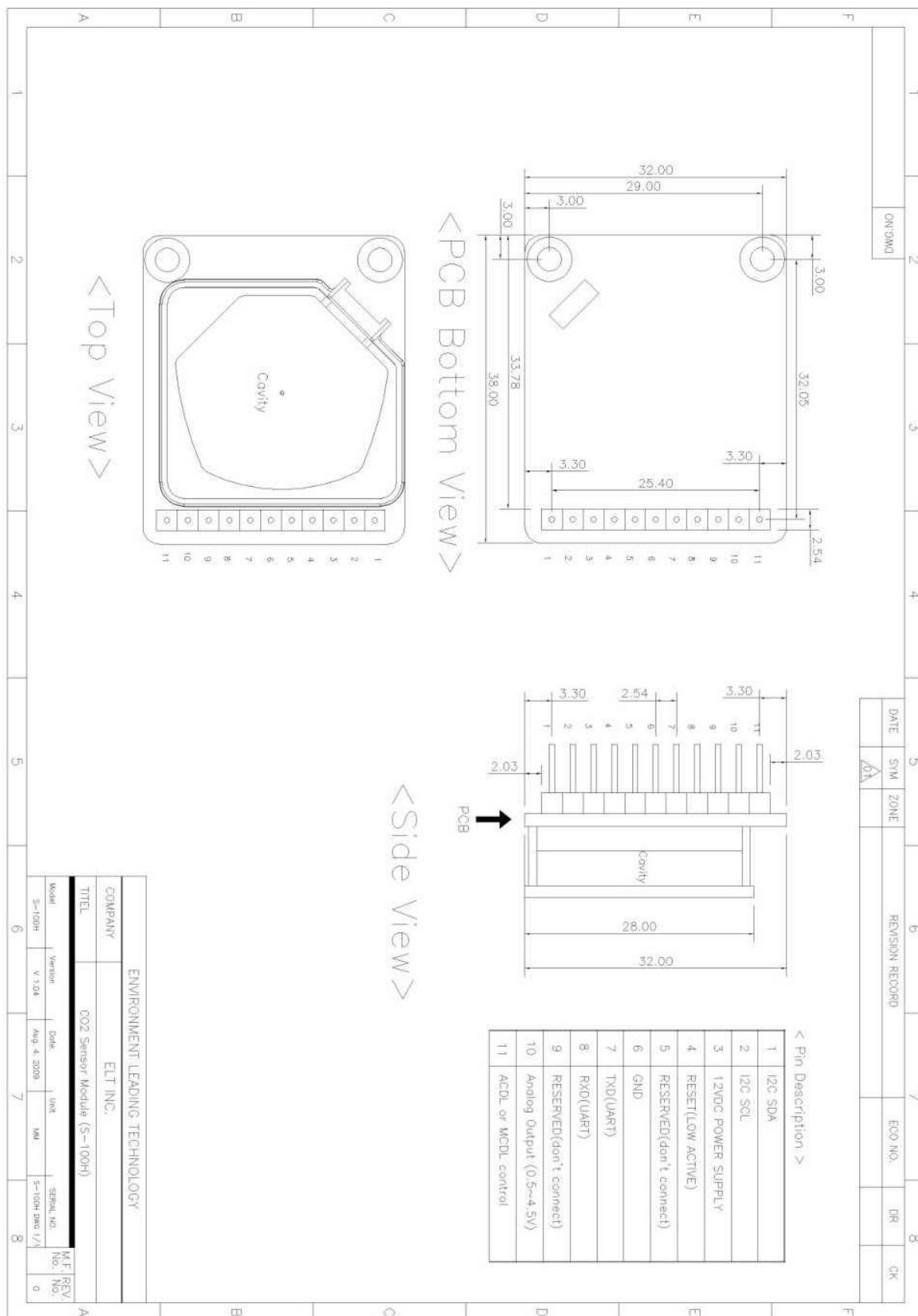

Output Descriptions

Analog Voltage Output

Output Range	0.5 ~ 4.5V (linear output)
Output Resolution	12 bits
Minimum Road(Rm)	10 KΩ

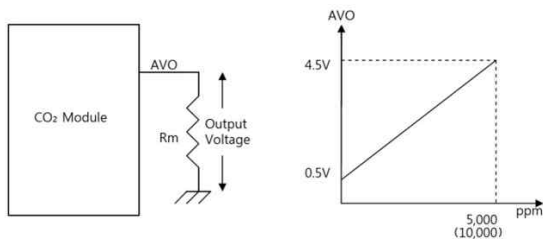

Data Format

B1	B2	B3	B4	B5	BL	'p'	'p'	'm'	CR	LF
----	----	----	----	----	----	-----	-----	-----	----	----

B1 ~ B5	5 byte CO2 density string
BL	Blank: 0x20
'ppm'	'ppm' string
CR	Carriage return : 0x0D
LF	Line feed : 0x0A

EX) In case 1,255 ppm,
 0x20 0x31 0x32 0x35 0x35 0x20 0x70 0x70
 0x6D 0x0D 0x0A
 '1,255 ppm<CR> <LF>'

Block Diagram

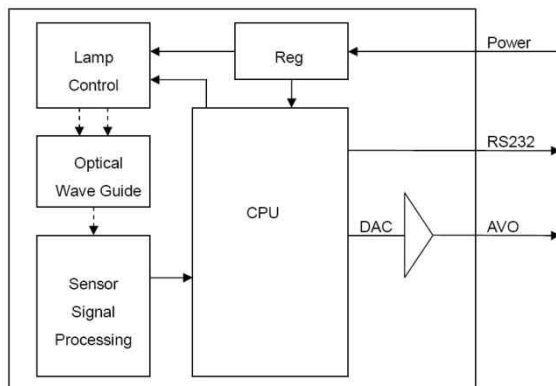

I2C Communication

(Only Slave Mode Operation)

Internal pull up resistor
 Slave Address : 0x31
 Slave Address Byte :
 Slave Address(0x31) 7 Bit + R/W 1 Bit

Bit7	Bit6	Bit5	Bit4	Bit3	Bit2	Bit1	Bit0
0	1	1	0	0	0	1	R/W Bit

R/W Bit : Read = 1/Write = 0

When reading the data, Slave Address Byte is 0x63

When writing the data, Slave Address Byte is 0x62

UART Protocol

Item	Description
Baud rate	38,400 BPS
Parity	No Parity
Number of Bits	8
Stop Bit	1

Data Transmit

Interval : 3 seconds

Handshake protocol : None (Data is transmitted to outer device periodically)

Block Diagram

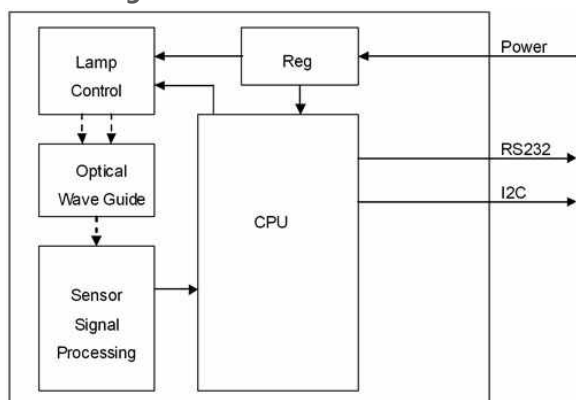

Transmission Sequence in Master

- 1) I2C Start Condition
- 2) Write Command(Slave Address + R/W Bit(0) = 0x62) Transmission and Check Acknowledge
- 3) Write Command(ASCII 'R' : 0x52) Transmission and Check Acknowledge
- 4) I2C Stop Command
- 5) I2C Start Command
- 6) Read Command(Slave Address + R/W Bit(1) = 0x63) Transmission and Check Acknowledge
- 7) Read 7 Byte Receiving Data from Module and Send Acknowledge
(Delay at least 1ms for reading each byte)

Configuration	CO ₂	reserved	reserved	reserved	reserved
1 Byte	2 Byte	0x00	0x00	0x00	0x00

0	0	0	0	1	0	0	0
---	---	---	---	---	---	---	---

Calibration Set Feature

No	Option	Recalibration Period	Default Function
1	Factory Calibration	Once before shipment	10 minute Manual Recalibration (so called 'MCDL')
2	ACDL	3days, every 30days	

S-100H model is designed to support 10 minutes Recalibration (so called MCDL: Manual Compensation in Dimming Light') as default function and either of two (the Factory Calibration or ACDL ; Automatic Compensation in Dimming Light) is equipped optionally.

10 minute Re-Calibration Method (MCDL)

- Method 1. Using pin-signal of S-100H, Apply TTL Low signal to pin 11 for 11 minutes, or
- Method 2. Using Jig Board (TRB-100: Test and Recalibration Board, On sale as option).

※ To activate MCDL function, the user's application must be designed to give Low Signal on 11rd pin of S-100H Board.

TCC ELT Corp.

A-601, Woorim Lions Valley, Gasan-dong, Geumchun-gu,
Seoul 153-803, KOREA
Phone : +82-2-2026-3177
Fax : +82-2-2026-3179
<http://www.tccelt.co.kr>

TCC ELT

Subject to change without notice. Printed in KOREA
2013 TCC ELT All rights reserved.
2013. April.